



5000L-SM

Fixture Type:

5000 WATT

5000L

The ProLine 5000L Tungsten-Halogen
10" Fresnel

Power and versatility make this instrument a workhorse as a keylight, backlight or kicker. The 5000L features a front door with spring action top accessory ear, heavy-duty on-board switch, a short lead for grid use or a 25' cable for stand mounting. This unit also comes with 250 mm short focus lens, safety screen, tubular steel yoke with 1 1/8" pin or heavy-duty pipe clamp, cord wrap and hinged filter frame. This fixture accepts all standard 13" (33 cm) accessories. Also available for this unit are 4-leaf or 8-leaf barndoor, a 3-in-1 snoot set, and a full compliment of scrims. This unit is available in stand mounted, hanging and pole operated versions. Included in every Proline fixture is Altman's new "F/S EZ Glide System" which allows the tray assembly to flood and spot with ease.

Specifications subject to change without notice

Features

- Rugged lightweight die-cast and extruded aluminum housing
- Rib design for superior strength and ventilation
- Easy operating focusing control with Teflon guides (see side photo)
- Spring loaded top accessories latch
- Lightweight, tubular steel yoke
- Non-corroding materials and hardware
- Hinged filter frame included
- Ventilation Stack
- Wire safety screen included
- U.L., c.U.L. and CE listed for 5000 watts
- Made in the USA



F/S EZ Glide System

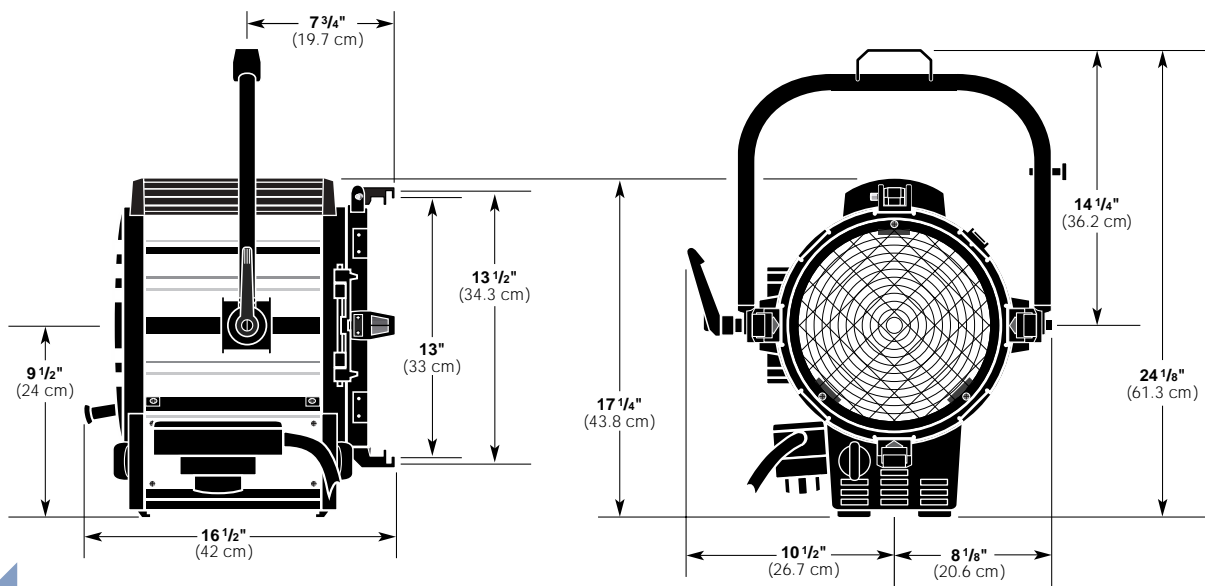

Specifications

Housing: Die-cast and extruded aluminum construction.

Materials: Construction employs all corrosion resistant materials and hardware.

Yoke: Tubular steel yoke with 1/2" (12.7 mm) opening and Kipp™ handle.

Reflector: Spherical, super pure aluminum reflector finished with a thermal brightening process.

Lens: Thermal shock resistant, 9.8" (250 mm) borosilicate glass Fresnel Lens.

Socket: Mogul bi-post, G38 type.

Rating: 5000 watt 120/240 volt AC/DC operation.

Focusing: Reflector, socket and lamp carriage, controlled with a Hi-Temp front and rear focusing knob, are driven along Teflon guide rods by a worm gear.

Accessories: Front end accessory holder accepts 13" (33 cm) accessories.

Finish: Etched metallic finish with a clear anodized coating, trimmed with a black epoxy sandtex, electrostatic application.

Weight: Approx; 40 lbs. (18.2 kg.) for 5000L-HM.
Approx; 44 lbs. (20 kg.) for 5000L-SM.
Approx; 43 lbs. (19.4 kg.) for 5000L-PO.

ACCESSORIES SUPPLIED WITH STANDING MODEL	
72-0076	F10 Front Mesh
F-CRL	Long Cord Wrap
F10-FF	Hinged Filter Frame
F-SAL	Combination 5/8" x 1 1/8" Spigot
---	25' Power Cord with Heavy-Duty On-Board Switch

ACCESSORIES SUPPLIED WITH HANGING MODEL	
72-0076	F10 Front Mesh
F-CRL	Long Cord Wrap
F10-FF	Hinged Filter Frame
510	Malleable Iron Pipe Clamp
---	36" (91.44 cm) Power Cord

ACCESSORIES SUPPLIED WITH POLE OPERATED UNIT	
72-0076	F10 Front Mesh
F-CRL	Long Cord Wrap
F10-FF	Hinged Filter Frame
F-SAL	Combination 5/8" x 1 1/8" Spigot
---	36" (91.44 cm) Power Cord

ADDITIONAL ACCESSORIES	
F10-BD4	4 Leaf Barn Door
F10-BD8	8 Leaf Barn Door
F10-SN	3-in-1 Snoot Set
F10-FS	Full Single Scrim
F10-HS	Half Single Scrim
F10-FD	Full Double Scrim
F10-HD	Half Double Scrim

LAMP DATA

Watts	Volts	Lamp Code	Color Temp(K°)	Rated Life	Rated Lumens
5000	120	DPY	3200	500	145,000
5000	220/240	---	3200	500	135,000

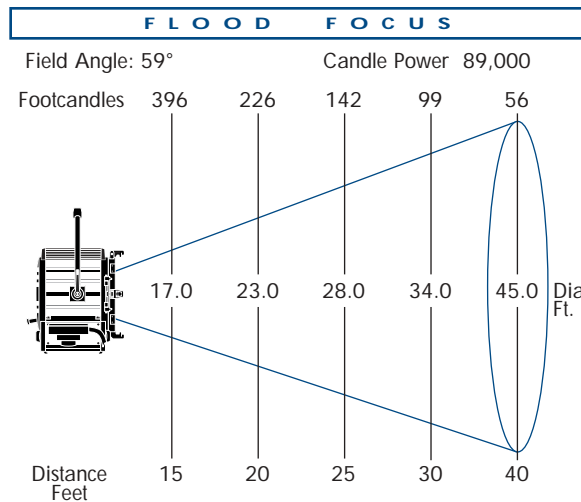
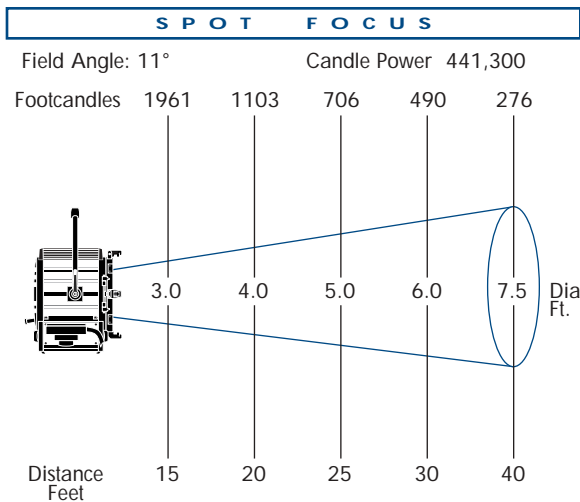

Calibrated CCD Camera Measurements with DPY LAMP.